

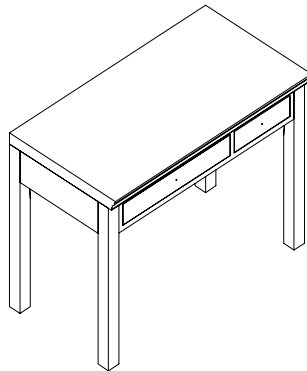

B-Cubed 3103 Desk - w/ Feet



Thank you for purchasing our products. Assembly of this product requires a phillips screwdriver.

Lay out parts on a non-abrasive surface to avoid scratching finish.

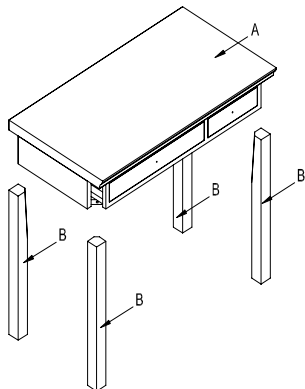

NO.	DRAWING	DESCRIPTION	Q'TY
A		TOP ASSEMBLY	1
B		LEGS	4

NO.	DRAWING	DESCRIPTION	Q'TY
C		HEXAGONAL BOLT	8
D		LEVELERS	4
E		HEXAGONAL WRENCH	1
F		KNOB	2
G		KNOB SCREW	2

STEP 1

Identify and count all parts using diagram above.

STEP 2

Identify and count all hardware.

Step 3

Remove Drawers from top assembly (A). Attach Knobs (F) to drawer fronts using Knob Screw (G).

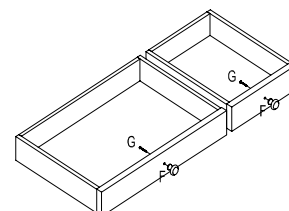
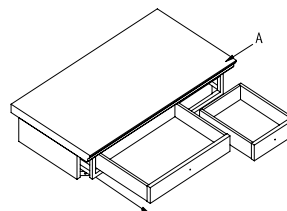

Step 4

Thread Leveler (D) into threaded inserts in bottom of Leg (B) (4 legs). Lay Top panel (A) on non-abrasive surface with underside of top facing up. Attach legs to underside of top by threading 2 Bolts (C) thru corner cleat and into the threaded inserts on legs (4 legs).

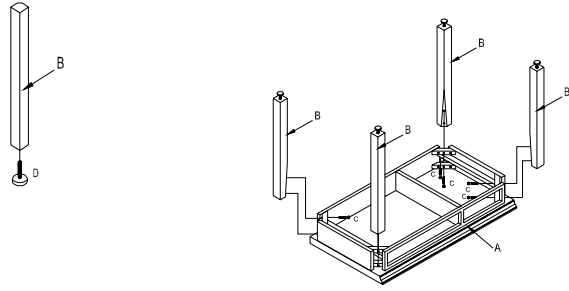

Step 5

Turn desk assembly upright. Put drawers back into desk assembly

