

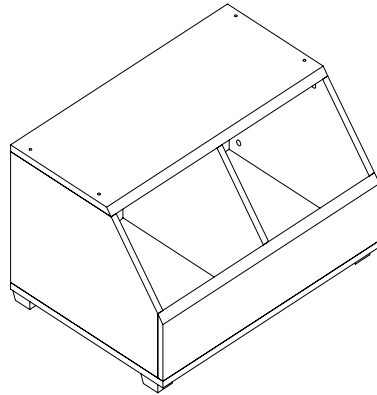

**B-Cubed 3104 Base Storage w/ Feet**



**Thank you for purchasing our products. Assembly of this product requires a phillips screwdriver.**

**Lay out parts on a non-abrasive surface to avoid scratching finish.**

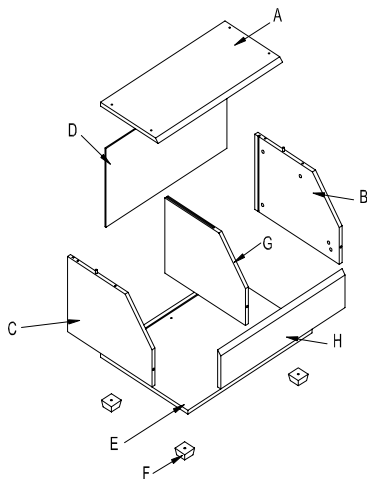

NO.	DRAWING	DESCRIPTION	QTY	NO.	DRAWING	DESCRIPTION	QTY
A		TOP	1	E		BOTTOM	1
B		RIGHT END	1	F		FEET	5
C		LEFT END	1	G		VERTICLE DIVIDER	1
D		CUBE BACK	1	H		FRONT PANEL	1

NO.	DRAWING	DESCRIPTION	QTY
I		MINIFIX CAM	11
J		MINIFIX CONNECTING BOLT	11
K		WIRE GUIDE	1
L		WIRE GUIDE	1
M		PLASTIC CAPS	8
L		ANGLE BRACKET	4
M		WOOD SCREW 4.0*14	14
N		SECURE CLIPS	2
O		HEADLESS ROD	5
P		ANTI TIP	1

**STEP 1**

Identify and count all parts using diagram above.

**STEP 2**

Identify and count all hardware.

### Step 3

Lay Bottom (E) w/ groove facing down on a non-abrasive surface. Screw Headless Rod (O) into threaded inserts (5 places). Attach Feet (F) screwing them into the opposite end of headless rod. Square the feet up to the edges.

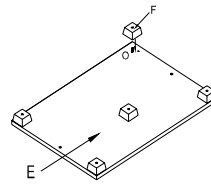

### STEP 4

Lay Top panel (A) & Bottom panel (E) w/ grooves facing up on non-abrasive surface. Thread Minifix Connecting Bolts (J) into threaded inserts (8 places). Tighten bolts using phillips screw driver. Insert Wire Guide (K) into pre-drilled holes on Bottom. Insert Wire Guide (L) into pre-drilled holes on Top.

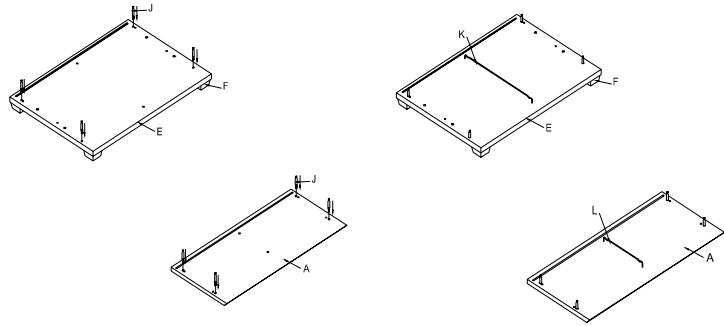

### STEP 5

Attach Left and Right Ends (B & C) by Aligning the predrilled holes in the edges to the Minifix Connecting Bolts in Bottom (E). Make Sure parts are seated tightly together. Insert the Minifix Cams (I) into the predrilled holes in End Panels (4 places) - Securely tighten Minifix Cams using phillips head screw driver.

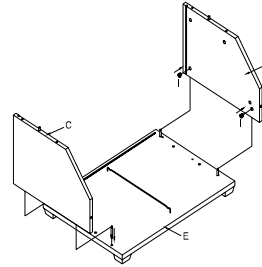

### STEP 6

Slide Cube Back (D) into grooves on Ends and Bottom.

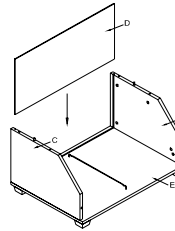

### STEP 7

Attach Top (A) by Aligning the Minifix Connecting Bolts to the predrilled holes in top edges of End Panels. Make sure that all parts are seated tightly together. Insert the Minifix Cams (I) into the predrilled holes in Ends (4 places) - Securely tighten Minifix Cams using phillips head screw driver. Slide Vertical Divider (G) in by aligning grooves in edges with wire guides. Attach Front Panel (H) by threading Minifix Connecting Bolts (J) into threaded inserts (3 places). Align bolts to pre-drilled holes in front edge of ends and divider. Seat in tightly. Securely tighten Minifix Cams using phillips head screw driver. Insert Plastic Cap (M) to cover Minifix Cam heads (11 places).

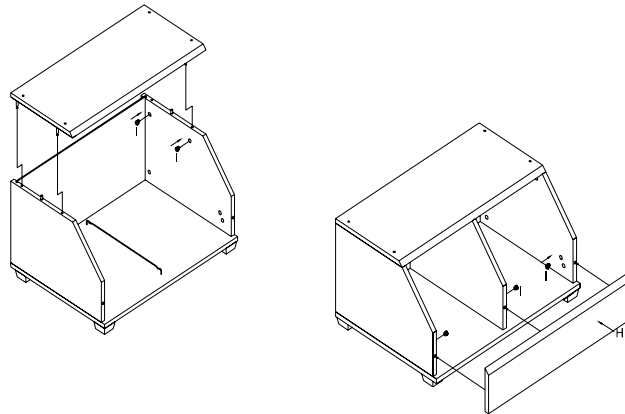

### STEP 8

Attach Angle Bracket (L) using Wood Screw (M) in 4 corners on back of Base Cabinet.

At the location of the pilot holes in the back panel attach screws thru the back panel into vertical divider.

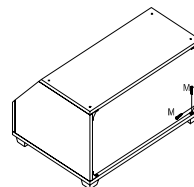

### Note:

Stacking Pins (K) are used to align cubes when stacking them on a base. Secure clips (N) are used to secure cubes together when stacking. Wall configurations can be one of our pre-configured walls or custom.

Typical Stacking Pin placement when stacking Cubes

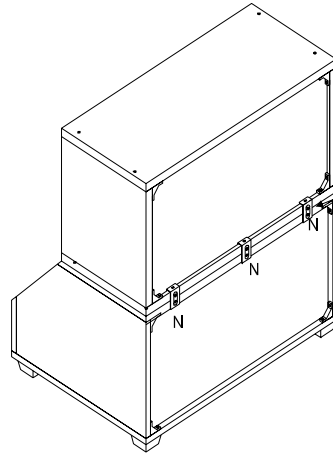
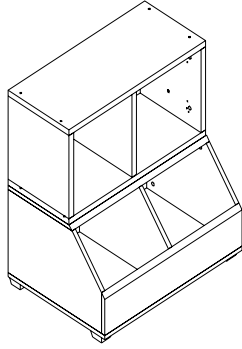
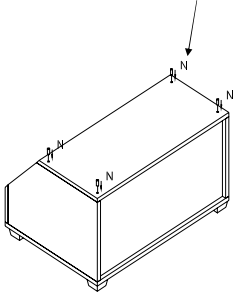

Typical Secure Clip placement when securing cubes together

