

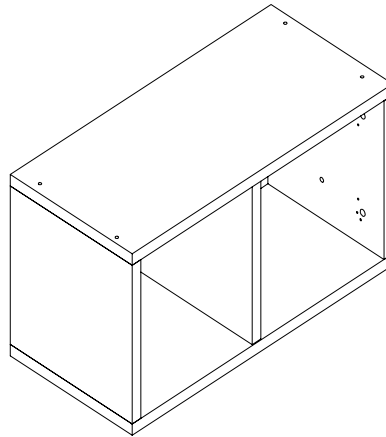

BOLTON

FURNITURE





B-Cubed 3202 Cube - Double



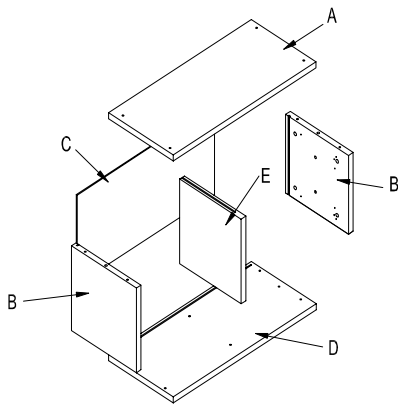







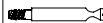

Thank you for purchasing our products. Assembly of this product requires a phillips screwdriver.

Lay out parts on a non-abrasive surface to avoid scratching finish.



NO.	DRAWING	DESCRIPTION	Q'TY
A		TOP	1
B		CUBE END	2
C		CUBE BACK	1
D		BOTTOM	1
E		VERTICLE DIVIDER	1

NO.	DRAWING	DESCRIPTION	Q'TY
F		MINIFIX CAM	8
G		MINIFIX CONNECTING BOLT	8
H		WIRE GUIDE	2
I		PLASTIC CAPS	8
J		JOINT CONNECTOR BOLT	2
K		JOINT CONNECTOR SLEEVE NUT	2
L		PLASTIC CAPS	4
M		STACKING PINS	4
N		ANGLE BRACKET	4
O		WOOD SCREW 4.0*14	8
P		SECURE CLIPS	3

STEP 1

Identify and count all parts using diagram above.

STEP 2

Identify and count all hardware.

STEP 3

Lay Top panel (A) & Bottom panel (D) w/ grooves facing up on non-abrasive surface. Thread Minifix Connecting Bolts (G) into threaded inserts (8 places). Tighten bolts using phillips screw driver. Insert Wire Guide (H) into pre-drilled holes.

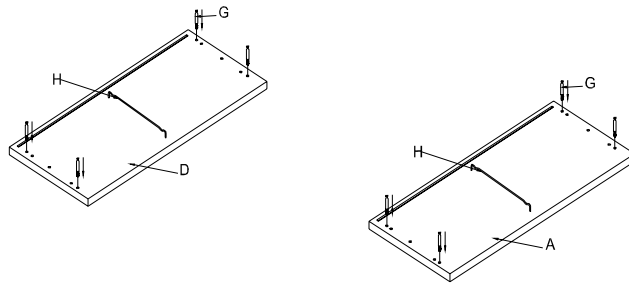

STEP 4

Attach Cube Ends (B) by Aligning the predrilled holes in the edges to the Minifix Connecting Bolts in Bottom (D). Make Sure parts are seated tightly together. Insert the Minifix Cams (F) into the predrilled holes in Cube Ends (4 places) - tighten Minifix Cams using phillips head screw driver.

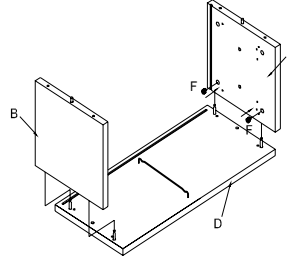

STEP 5

Slide Cube Back (C) into groves on Ends and Bottom.

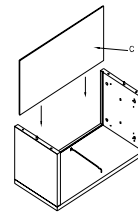

STEP 6

Attach Top (A) by Aligning the Minifix Connecting Bolts to the predrilled holes in the edges of Cube Ends. Make sure that all parts are seated tightly together. Insert the Minifix Cams (F) into the predrilled holes in Cube Ends (4 places) - tighten Minifix Cams using phillips head screw driver. Insert Plastic Cap (I) to cover all 8 Minifix Cam heads. Slide Vertical Divider (E) in by aligning grooves in edges with wire guides.

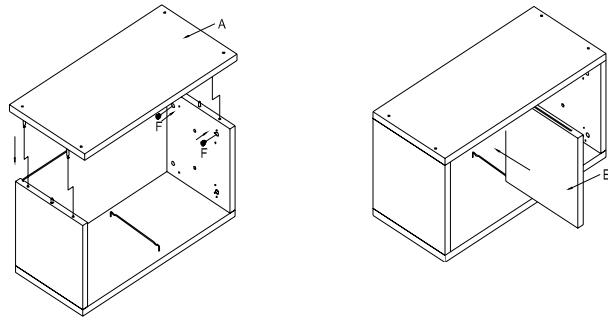

STEP 7

Attach Angle Bracket (N) using Wood Screw (O) in 4 corners on back of Cube.

At the location of the thru holes in the back panel, attach screws thru the back panel into the vertical divider.

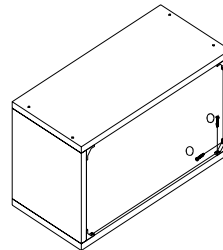

Note:

Joint Connector Bolt (J), Joint Connector Sleeve Nut (K) and Plastic Cap (L) are used in connecting cubes together in horizontal configurations. Stacking Pins (M) are used to align cubes when stacking. Secure clips (P) are used to secure cubes together when stacking. Wall configurations can be one of our pre-configured walls or custom.

