

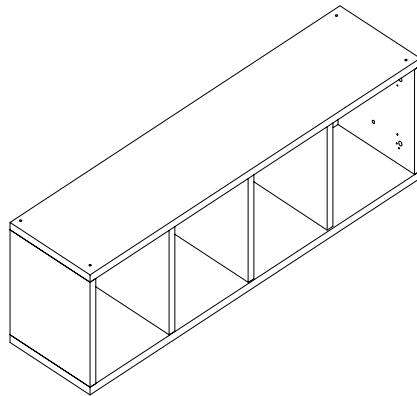

**B-Cubed 3204 Cube - Quad**



**Thank you for purchasing our products. Assembly of this product requires a phillips screwdriver.**

**Lay out parts on a non-abrasive surface to avoid scratching finish.**

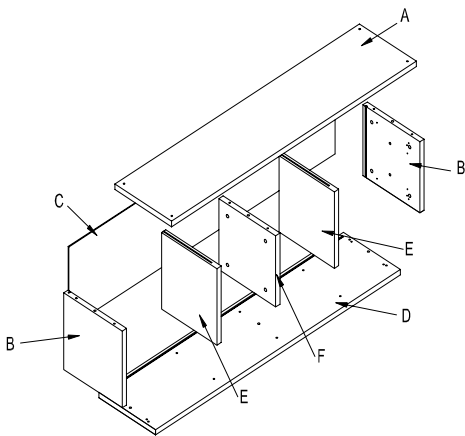

NO.	DRAWING	DESCRIPTION	QTY
A		TOP	1
B		CUBE ENDS	2
C		BACK	1
D		BOTTOM	1
E		VERTICLE DIVIDER	2
F		FIXED DIVIDER	1

NO.	DRAWING	DESCRIPTION	Q'TY
G		MINIFIX CAM	12
H		MINIFIX CONNECTING BOLT	12
I		WIRE GUIDE	4
J		PLASTIC CAPS	12
K		JOINT CONNECTOR BOLT	2
L		JOINT CONNECTOR SLEEVE NUT	2
M		PLASTIC CAPS	4
N		STACKING PINS	4
O		ANGLE BRACKET	4
P		WOOD SCREW 4.0*14	14
Q		SECURE CLIPS	3

**STEP 1**

Identify and count all parts using diagram above.

**STEP 2**

Identify and count all hardware.

**STEP 3**

Lay Top panel (A) & Bottom panel (D) w/ grooves facing up on non-abrasive surface. Thread Minifix Connecting Bolts (H) into threaded inserts (12 places). Tighten bolts using phillips screw driver. Insert Wire Guide (I) into pre-drilled holes (4 places).

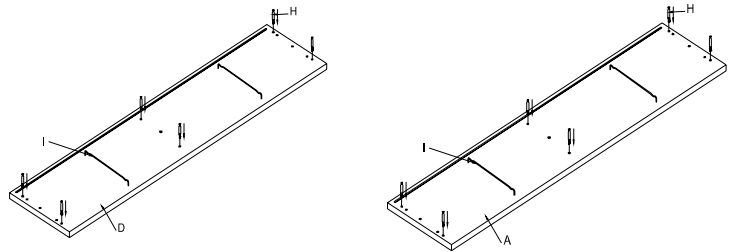

**STEP 4**

Attach Cube Ends (B) and Fixed Divider (F) by Aligning the predrilled holes in the edges to the Minifix Connecting Bolts in Bottom (D). Make Sure parts are seated tightly together. Insert the Minifix Cams (G) into the predrilled holes in Ends and Fixed Divider (6 places) - Securely tighten Minifix Cams using phillips head screw driver.

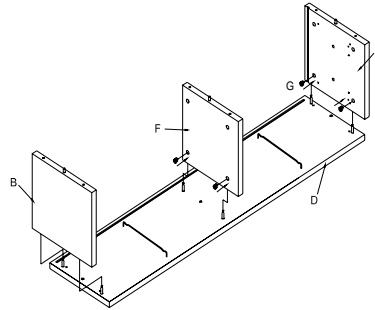

**STEP 5**

Slide Cube Back (C) into groves on Ends and Bottom.

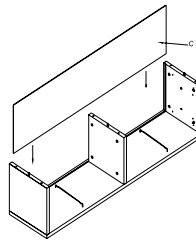

**STEP 6**

Attach Top (A) by Aligning the Minifix Connecting Bolts to the predrilled holes in the edges of Cube Ends and divider. Make sure that all parts are seated tightly together. Insert the Minifix Cams (G) into the predrilled holes in Cube Ends and Divider (6 places) - Securely tighten Minifix Cams using phillips head screw driver. Insert Plastic Cap (I) to cover all 12 Minifix Cam heads. Slide Vertical Divider (E) in by aligning grooves in edges with wire guides (2 places).

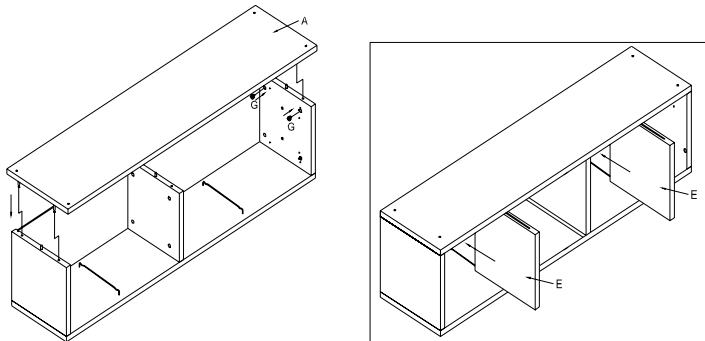

**STEP 7**

Attach Angle Bracket (O) using Wood Screw (P) in 4 corners on back of Cube.

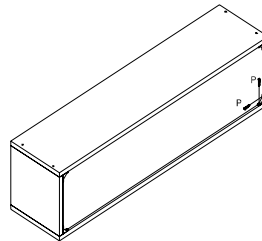

At the location of the pilot holes in the back panel, attach 6 screws thru the back into the vertical dividers and fixed divider.

**Note:**

Joint Connector Bolt (K), Joint Connector Sleeve Nut (L) and Plastic Cap (M) are used in connecting cubes together in horizontal configurations. Stacking Pins (N) are used to align cubes when stacking. Secure clips (Q) are used to secure cubes together when stacking. Wall configurations can be one of our pre-configured walls or custom.

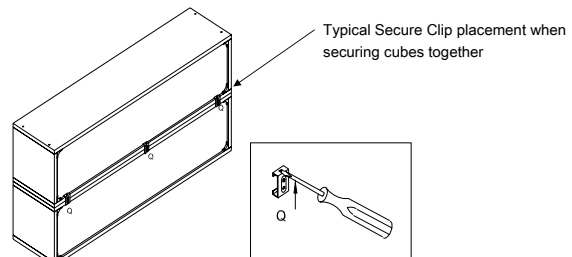
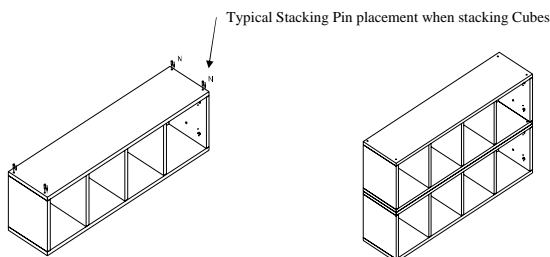

**This portion of the Assembly requires a cordless drill and a 1/4" drill bit.**

Pre-Configured Assemblies

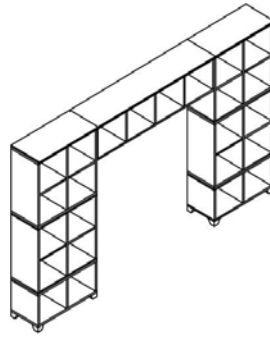

120 " Bridge Wall Full - BW01X

Step 1

Finish pre-assembly of all individual Cubes and Bases.

Step 2

Determine where you want the final assembly of your wall system to be located on your wall.

Step 3

Build your left tower - starting with the Base Cabinet or Cubes w/ feet. Stack the cubes using stacking pins. Secure the Cubes together using the Secure Clips. Do not place the top Cube in position at this time. The top cubes and bridge will be assembled together before they are put into place. Using levelers in the feet make sure tower assembly is level and plum to wall.

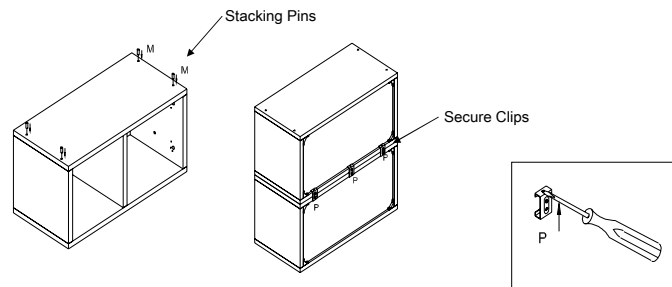

\*Typical assembly using stacking pins and secure clips.

Step 4

Determine Spacing between Left and Right Tower using Cube Quad - Build the right hand tower using the same instructions as in step 3.

\*Typical use of bridge to determine spacing between towers.

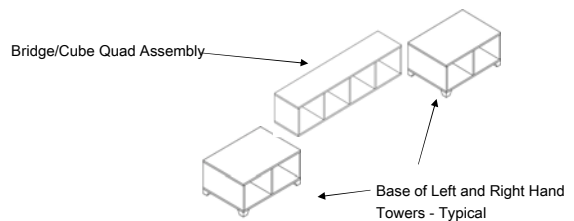

Step 5

Determine what connector holes to drill thru to connect Cube Quad to left and right top cubes.

The end panels of every cube have pre-drilled connector holes that are used to connect the Cube Quad/Bridge to the top cubes of each tower - these holes are drilled half way thru the ends. These holes determine the location where the cubes will be connected.

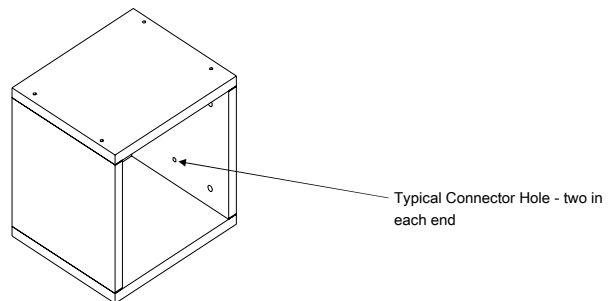

Step 6

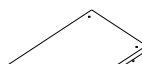

Using a 1/4" drill bit - drill the connector holes thru on the Cube Quad - 4 places - left and right hand ends

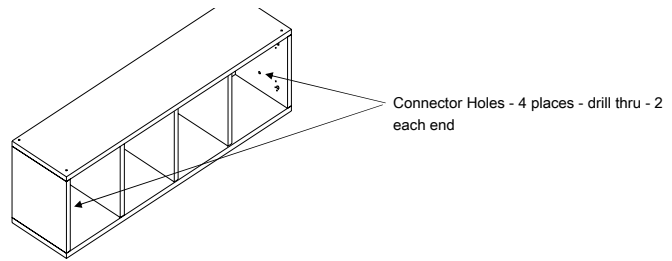

**Step 7**

**Top Cube LEFT HAND TOWER** - The connector holes to be drilled thru will be on the right hand end panel of this cube. Using a 1/4" drill bit - drill the thru holes (two places). If the top Cube is a Double / Double only drill the top two connector holes in the right hand end panel.

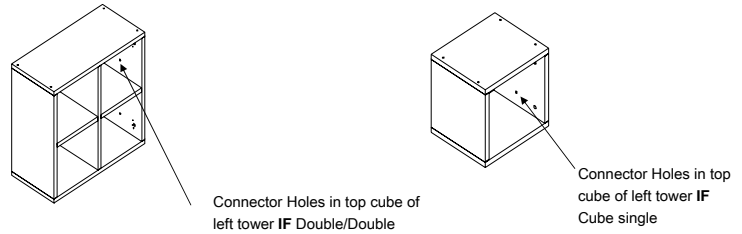

**Step 8**

**Top Cube RIGHT HAND TOWER** - The connector holes to be drilled thru will be on the left hand end panel of this cube. Using a 1/4" drill bit - drill the thru holes (two places). If the top Cube is a Double / Double only drill the top two connector holes in the left hand end panel.

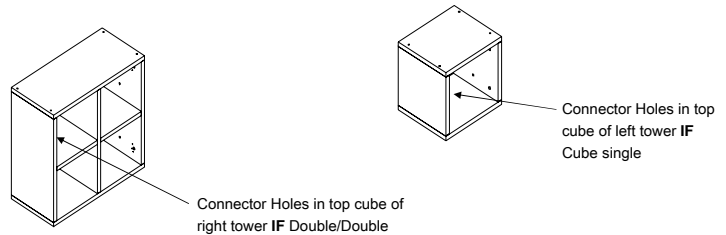

**Step 9**

Connect Cube Quad and top cubes of each tower. Position the Cube Quad and cubes for the left and right hand towers on their backs - align the connector holes at all locations. Using the Joint connector bolt and joint connector sleeve, connect the Cube Quad and left and right cubes together. Make sure all cubes are flush at top. tighten all connector bolts.

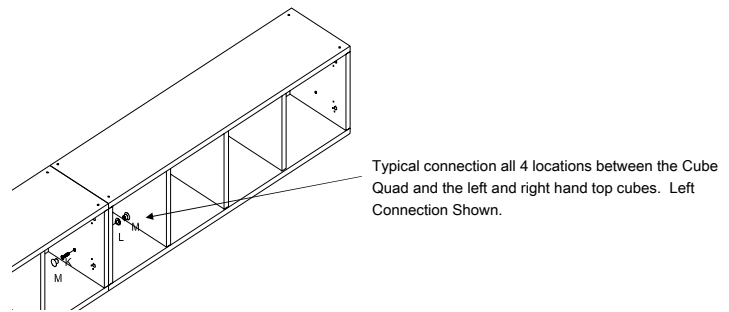

**Step 10**

With all three cubes connected together, lift assembly and position it into place on the left and right hand towers - align the stacking pin holes in all locations.

Insert Stacking pins and secure Crowns. Using mounting plates - attach crowns to cube assemblies.

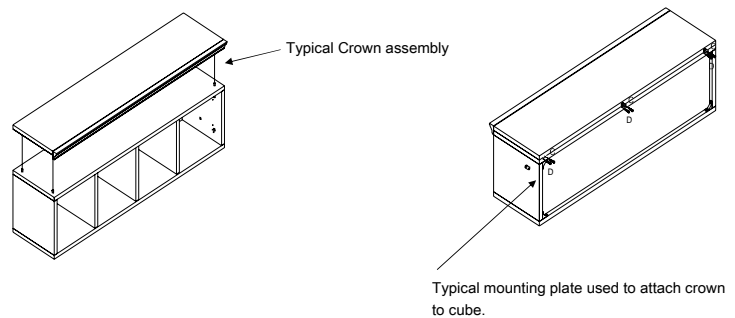

**Typical Finished Wall Assembly - Cube Quad / Bridge**

