

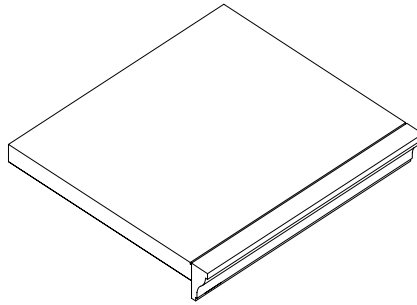

B-Cubed 3301 Crown - Single



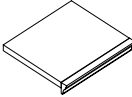

Thank you for purchasing our products. Assembly of this product requires a phillips screwdriver.

Lay out parts on a non-abrasive surface to avoid scratching finish.

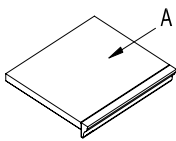
NO.	DRAWING	DESCRIPTION	Q'TY
A		TOP CROWN	1



NO.	DRAWING	DESCRIPTION	Q'TY
B		STACKING PINS	4
C		MENDING PLATES	2
D		WOOD SCREW 4.0*14	4

Note: The Crown - Single is the top on a 3201 Cube Single. When stacking cubes, the Crown - Single is the top on the uppermost Cube - Single.

STEP 1
Identify and count all parts using diagram above.

STEP 2
Identify and count all hardware.

STEP 3

Insert 4 stacking pins (B) in pre-drilled holes in top of Cube - Single. Align holes on underside of Crown - Single (A) to stacking pins in top of Cube Single. Seat top down firmly.

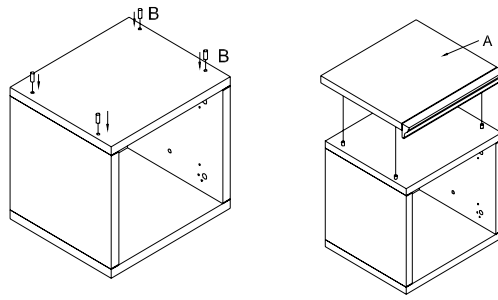

STEP 4

Secure Crown - Single to Cube - Single by attaching Mending Plate (C) in back edges of the Cube - Single and Crown - Single using Wood Screw (D). Attach the Mending Plates in two places.

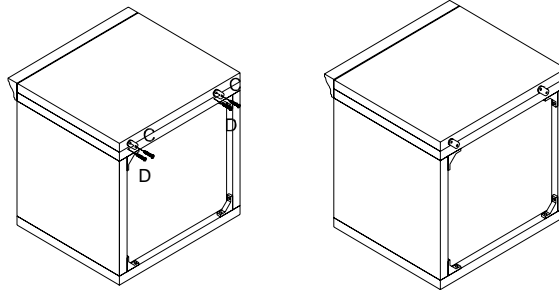

STEP 5

The Cube - Single w/ Crown is now complete. The Cube - Single w/ Crown can be used as a stand alone piece or will be the top assembly in a stack-a-ble configuration.

