

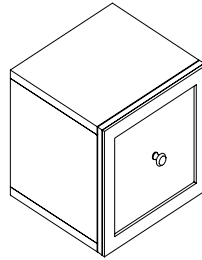

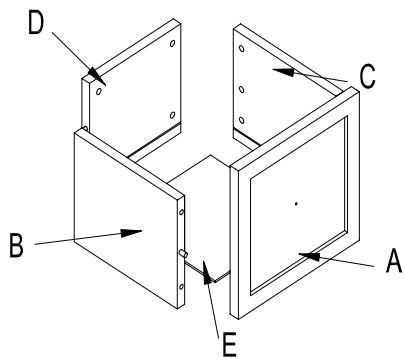

B-Cubed 3404 Drawer - Cube Single





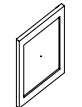





Thank you for purchasing our products. Assembly of this product requires a phillips screwdriver.

Lay out parts on a non-abrasive surface to avoid scratching finish.



NO.	DRAWING	DESCRIPTION	QTY
A		DRAWER FRONT	1
B		DRAWER BOX SIDE LEFT	1
C		DRAWER BOX SIDE RIGHT	1
D		DRAWER BOX BACK	1
E		DRAWER BOTTOM	1

NO.	DRAWING	DESCRIPTION	QTY
F		DRAWER TRACK	2
G		DRAWER CHANNEL	2
H		TRACK AND CHANNEL SCREWS	8
I		KNOB	1
J		KNOB SCREW	1
K		MINIFIX CAM	8
L		MINIFIX CONNECTING BOLT	8
M		PLASTIC CAPS	8

Note: The Drawer Cube Single is an optional drawer that can be put in a 3201 Cube Single.

STEP 1

Identify and count all parts using diagram above.

STEP 2

Identify and count all hardware.

STEP 3

Lay Left and Right Drawer Box Sides (B) & (C) w/ grooves facing up on non-abrasive surface. Thread Minifix Connecting Bolts (L) into threaded inserts (4 places). Tighten bolts using phillips screw driver.

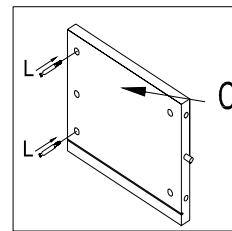
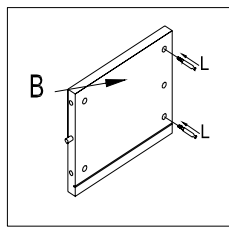

STEP 4

Insert the Minifix Cams (K) into the predrilled holes in Drawer Box Back (D). Align Minifix bolts in Drawer Box Sides to Minifix Cam holes in edges of Drawer Box Back. Securely tighten Minifix Cams using phillips head screw driver.

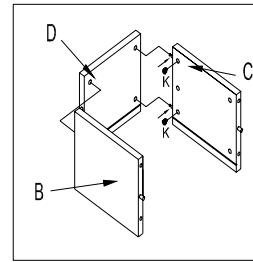
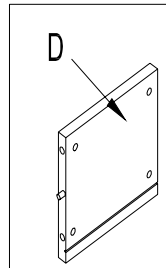

STEP 5

Slide Drawer Bottom (E) into grooves on Sides and into groove on Drawer Box Back.

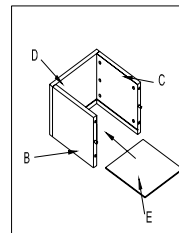

STEP 6

Lay Drawer Front (A) w/ groove facing up on non-abrasive surface. Thread Minifix Connecting Bolts (L) into threaded inserts (4 places). Tighten bolts using phillips screw driver. Insert the Minifix Cams (K) into the predrilled holes in Drawer Sides. Align Minifix bolts in Drawer Front to Minifix Cam holes in edges of Drawer Box Sides. Securely tighten Minifix Cams using phillips head screw driver.

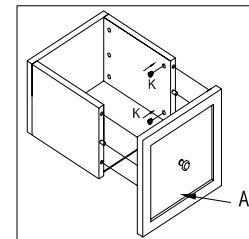
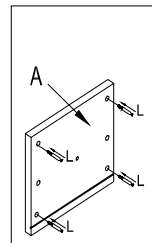

STEP 7

Attach Knob (I) using Knob Screw (J) to Drawer Front (A). Attach Drawer Track (F) to underside of Left and Rights Sides of Drawer Box assembly. Align holes in Drawer Track to pilot holes in left and right Drawer Box Sides. Screw into place using Track and Channel Screws (H).

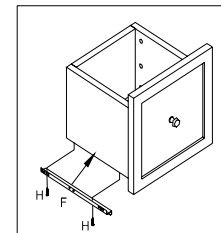
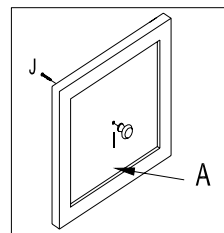

Step 8

Align Drawer Channel (G) to pre-drilled holes in Single Cube Ends. Screw into place using Track and Channel Screws (H) - 2 screws required for each drawer channel. Insert drawer in Cube Single.

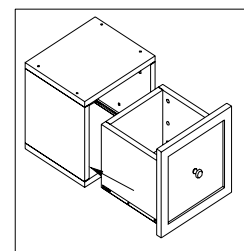
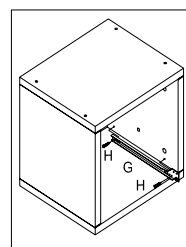

The Cube - Single w/ optional Drawer Box is now complete. The Cube - Single w/ drawer can be used as a stand alone piece or one of the cubes within a stack-able configuration.